



OPENIPC 200mW

User_Manual

Disclaimer

Before using this product, please carefully read this disclaimer. By using this product, you are deemed to have acknowledged and accepted all contents of this statement. This product is not suitable for minors under 18 years of age.

Wyvern Link is a new-generation digital video transmission project based on the open-source project OpenIPC. The OpenIPC system offers a high-definition digital video transmission experience at a low cost, with a high degree of freedom, allowing users to customize configurations to suit their needs. When using this product, please carefully read the user manual and precautions. Ensure the power supply is in good condition and the operation is correct. Our company assumes no civil or legal

responsibility for any personal injury or property damage (direct or indirect) caused by the use of this product.

Precautions

1. Please assemble and operate this product correctly as instructed in the manual.
2. Avoid dropping or hitting the product to prevent malfunctions.
3. Do not block the heat dissipation vents to prevent overheating.
4. If you feel any discomfort during use, stop immediately and only continue using the product with a doctor's permission.
5. Do not use this product under the influence of alcohol, drugs, medication, or when experiencing dizziness, fatigue, or a poor mental state.
6. Do not disassemble, modify, or use other parts and accessories that exceed the specified configuration requirements.
7. Do not use a damaged video transmitter to avoid short circuits, fires, etc.
8. Do not place this product in water.
9. Do not use this product in harsh environments (e.g., strong winds, rain, lightning, snow, etc.).
10. Do not use this product in a strong electromagnetic environment.

1. Product Description

The OpenIPC VTX 200mW Kit mainly includes:

- 1.OpenIPC VTX 200mW x1
- 2.Camera (Sony IMX415 sensor_14x14)..... x1
- 3.Antennas..... x2
- 4.Ethernet network card(the downloader board)..... x1
- 5.Mipi connection cable..... x1
- 6. 4-pin power connection cable..... x1
- 7. 8-pin downloader connection cable..... x1
- 8. Screw and accessory pack..... x1

Please check if the product specifications and quantity match your purchase.

2. Video Transmitter Interface

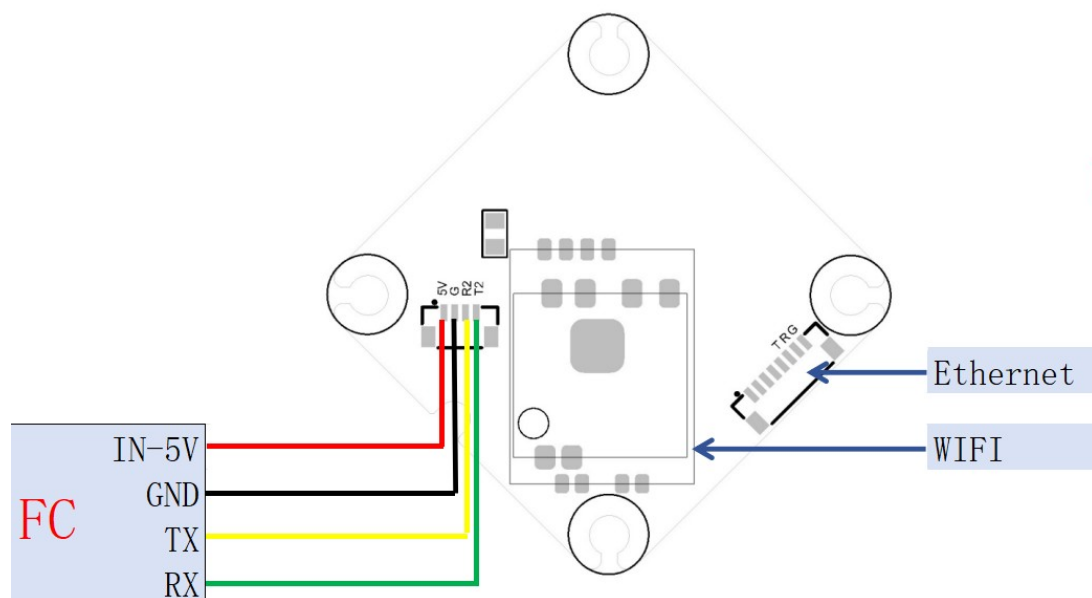

2.1 Cable Color Notes: From right to left: BAT (red), Gnd (black), Rx (yellow), Tx (green), .

2.2 Normal use does not require connecting the downloader board on the left; it is only used for debugging.

3. Video Transmitter Usage Instructions

Connect the video transmitter and antennas as shown in the wiring diagram.

- 3.1. Note that the Tx and Rx interfaces must be cross-connected.
- 3.2. The power supply range for the video transmitter is 5V.
- 3.3. On the flight controller (using Betaflight as an example), you need to change the connected port settings to enable peripheral VTX (MSP+Displayport), with a baud rate of 115200. Save and reboot.

端口 WIKI

注意：不是所有的组合都是有意义的，如果飞行控制器固件不能同时工作，为应串口的设置将会被重置。
 注意：不要关闭第一个串口的MSP选项，否则你可能需要重新烧录固件并清空（清空）所有设置。

标识符	设置/MSP	串行数字接收机	逻辑输出	传输器输入	外设
USB VCP	<input checked="" type="checkbox"/> 115200	<input type="checkbox"/>	已禁用 AUTO	已禁用 AUTO	已禁用 AUTO
UART1	<input type="checkbox"/> 115200	<input type="checkbox"/>	已禁用 AUTO	已禁用 AUTO	已禁用 AUTO
UART2	<input checked="" type="checkbox"/> 115200	<input type="checkbox"/>	已禁用 AUTO	已禁用 AUTO	VTX (MSP + D) 115200

You can then select and configure the OSD characters in the OSD tab of the flight controller configurator.

- 3.4. Connect the power supply and wait for the video transmitter to boot up. It takes about 20 seconds from power-on until an image appears. The default frequency is 132 (5660), and you need to set the VRx (receiver) to the same frequency. The default key is used for the transmitter.

Once the image appears, the OSD characters will be displayed on the screen.

Note: If the characters "Identifying Flight Controller..." appear on the screen, you need to check the connection between the video transmitter and the flight controller or the serial port settings on the flight controller.

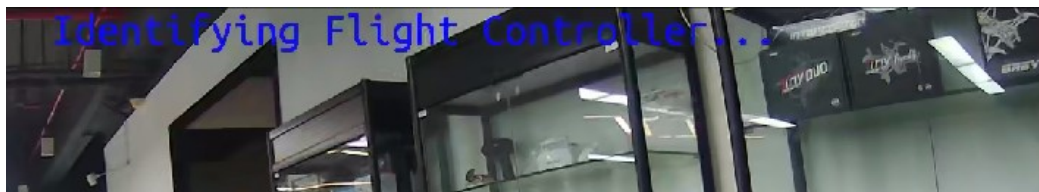

4. Changing Video Transmitter Parameters

4.1. With Flight Controller Connected

After correctly connecting and powering on the OpenIPC with the flight controller, an image should appear. Use the remote controller stick gestures to enter debug mode. In this mode, you can adjust various

flight/image settings for the OpenIPC via the remote controller. After making changes, save and reboot the video transmitter using the "save-reboot" command for the parameters to take effect.



Enter VTX menu



Move Up



Move Down



Move Left



Move Right/Enter



Exit Camera menu



Safeboot

After entering the VTX menu, the OSD will change to the style shown in the top-left corner of the image.

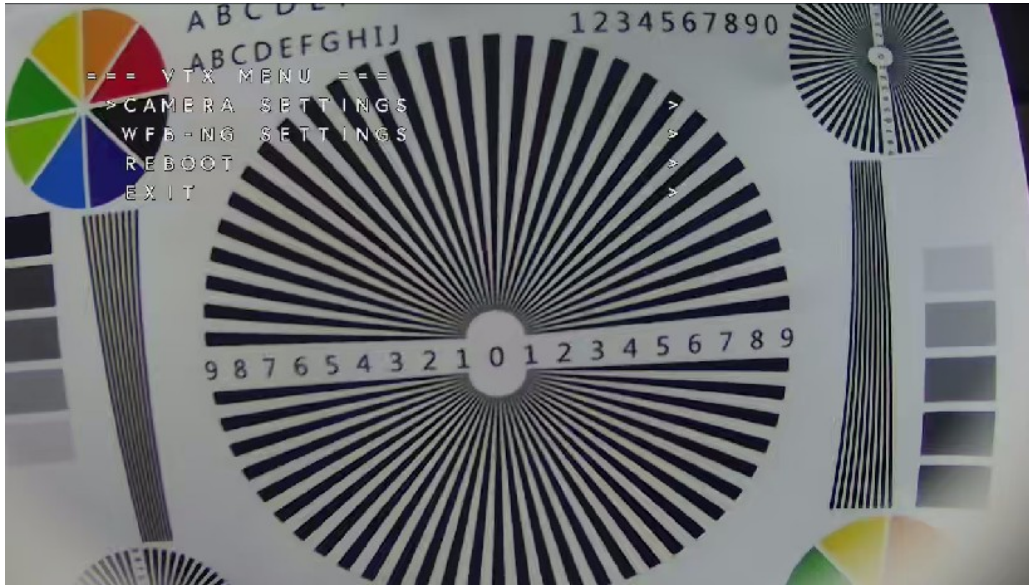

- 1) **CAMERA SETTINGS:** Mainly for changing camera parameters such as display brightness, contrast, saturation, and video resolution and frame rate.
- 2) **WFB-NG SETTINGS:** Mainly for changing video transmission parameters such as video card power and video transmission frequency.
- 3) **REBOOT:** Restarts the camera to apply the changes.
- 4) **EXIT:** Exits the VTX menu.

Common Function Examples:

Adjusting Frequency: Use remote controller gestures to enter the VTX menu, pull down the right stick to select **WFB-NG SETTINGS**, pull right to enter the parameter interface. Pull down the right stick to select **CHANNEL**, and use the right stick to move left or right to choose a frequency. After selecting, save the settings by confirming under **SAVE**, then reboot the video transmitter to update the parameters.

Adjusting Power: The prerequisite is the same as for adjusting the frequency: after entering the **WFB-NG SETTINGS** parameter interface,

pull down the right stick to select **driver_txpower_override**, and use the right stick to move left or right to choose a power level. After selecting, save the settings by confirming under **SAVE**, then reboot the video transmitter to update the parameters.

Adjusting Resolution: Use remote controller gestures to enter the VTX menu, pull right to enter the **CAMERA SETTINGS** interface, pull down the right stick to select **VIDEO**, pull right to enter the VIDEO parameter interface. Pull down the right stick to select the **SIZE** parameter. After selecting the desired resolution, save the settings by confirming under **SAVE**, then reboot the video transmitter to update the parameters.

Adjusting Bitrate: The prerequisite is the same as for adjusting the resolution: after entering the VIDEO parameter interface, select the **bitrate** parameter. After selecting the desired bitrate, save the settings by confirming under **SAVE**, then reboot the video transmitter to update the parameters.

Adjusting Frame Rate: The prerequisite is the same as for adjusting the resolution: after entering the VIDEO parameter interface, select the **fps** parameter. After selecting the desired frame rate, save the settings by confirming under **SAVE**, then reboot the video transmitter to update the parameters.

4.2. Without Flight Controller Connected

If not connected to a flight controller, you need to use the provided downloader board to log in to the OpenIPC system to change settings.

- 1) **Logging in to OpenIPC:** Connect the OpenIPC via the 8-pin cable to the downloader board, connect a network cable, and power it on. Wait for an image to appear, then log in to the OpenIPC system via SSH (using software like PuTTY). The username is **root** and the password is **12345**.
- 2) Use the command `vi /etc/wfb.conf` to enter the video transmission parameter file. Press the **i** key to enable modification mode. Use the keyboard arrow keys to move the cursor, then change the corresponding parameters. Press **Esc** to save the settings, then use **Shift + double-tap z** to exit the video transmission parameter file.
- 3) Use the command `vi /etc/majestic.yaml` to enter the camera parameter file. Press the **i** key to enable modification mode. Use the keyboard

arrow keys to move the cursor, then change the corresponding parameters. Press **Esc** to save the settings, then use **Shift + double-tap z** to exit the camera parameter file.

- 4) Use the `reboot` command to restart the video transmitter and apply the changes.

Common Function Examples:

Adjusting Frequency: Use the command `vi /etc/wfb.conf` to enter the video transmission parameter file. Find the **channel** parameter to adjust the frequency.

Adjusting Power: Use the command `vi /etc/wfb.conf` to enter the video transmission parameter file. Find the **driver_txpower_override** parameter to adjust the power.

Adjusting Resolution: Use the command `vi /etc/majestic.yaml` to enter the camera parameter file. Find the **size** parameter under **video0** to adjust the resolution.

Adjusting Bitrate: Use the command `vi /etc/majestic.yaml` to enter the camera parameter file. Find the **bitrate** parameter under **video0** to adjust the bitrate.

Adjusting Frame Rate: Use the command `vi /etc/majestic.yaml` to enter the camera parameter file. Find the **fps** parameter under **video0** to adjust the frame rate.